



ELMES Elektronik CB32 CONTROL PANEL
(ver. 4.00, 12.2014)
Installation and operation manual

INTRODUCTION	2
KEYPAD USE AND ARMING METHODS	3
ARMING & DISARMING OF ALARM SYSTEM.	3
1. <i>Arming & disarming alarm from CB32 panel keypad.</i>	3
2. <i>Operating CB32 panel using a remote.</i>	4
3. <i>Arming & disarming using a mobile phone.</i>	4
4. <i>Arming the system bypassing selected alarm zones.</i>	4
CB32 SELECTED FUNCTIONS DESCRIPTION	5
ALARM DETECTOR MONITOR	5
ANTI-SABOTAGE OF PROTECTION OF EXTERNAL DEVICES	5
OPERATION WITH WIRED ALARM DETECTORS	5
OPERATION WITH REMOTE CONTROL TRANSMITTER (REMOTE)	5
OPERATION WITH EXTERNAL WIRELESS SIREN	5
OPERATION WITH GSM MODULE.	6
CB32 PANEL CONFIGURATION AND FIRMWARE UPGRADE USING PC	6
MAIN MENU	7
ALARM EVENT MEMORY	7
FAILURE CHECK	7
SERVICE SETTINGS (S.S.)	7
1. <i>Event Memory</i>	7
2. <i>Password Change</i>	7
3. <i>Zone Settings</i>	7
4. <i>Outputs settings.</i>	9
5. <i>System users - adding, editing and removing a user.</i>	10
6. <i>System times settings.</i>	12
7. <i>Alarm notification by GSM module.</i>	13
8. <i>Auxiliary functions settings.</i>	14
9. <i>System arming signalling modes.</i>	16
10. <i>System Status</i>	16
SETTINGS RESET	17
RESETTING PASSWORD OF USER NUMBER 1.	17
CB32 RESTORE TO FACTORY SETTINGS (DEFAULT SETTINGS).	17
DESIGNING WIRELESS ALARM SYSTEM	17
POWER SUPPLY SOLUTIONS	18
ALARM SYSTEM WITH ELMES ELECTRONIC CB32 CONTROL PANEL	19
SPECIFICATION	22
LIMITED WARRANTY	23
FREQUENTLY ASKED QUESTIONS	24

INTRODUCTION

Elmes Electronic CB32 is a programmable, wireless alarm control panel designed for use in anti-burglary, anti-robbery, intrusion detection and access control installations in houses, apartments and offices. It operates with any Elmes Electronic made wireless detectors, transmitter RP501, remote control transmitters and some wired detectors. Its three 1A current fused alarm signaling outputs are intended for connecting external signaling devices such as sirens, bells strobes and automatic alarm notification devices as phone dialer. The panel features a real-time clock, non-editable memory log of last 256 events and may be programmed, if connected to Elmes Electronic GSM module, to send SMS alarm notifications, status and event monitoring as well as be armed and disarmed by mobile phone. The backlit LCD displays appropriate status information while numeric keypad allows convenient handling and programming of the control panel. In the event of AC power failure, dedicated software procedures initiate low energy consumption mode allowing 72-hour panel autonomy operation with just two internal 1800mAh AA type rechargeable batteries. The panel supports up to 16 system users and enables monitoring of up to 32 wireless and two parametric wired detectors identified as alarm zones. Each user and alarm zone can have any user defined 16 characters name.

The CB32 control panel also supports wireless detectors in wired alarm systems. It may be powered from the power supply line of the wired system, and its three signaling outputs can be connected to the alarm detection terminals of a wired control panel.

***WARNING!** This wireless control panel has been designed to be as effective as possible. However, there are circumstances that alarm system may fail to operate as expected for variety of reasons. Users and installers are warned that radio signals from wireless detectors and sensors may not reach the CB32 panel under all circumstances. Metal objects placed on radio transmission paths, deliberate jamming or other radio signal interference can seriously reduce operating range.*

General features of Elmes Electronic CB32 control panel:

- microprocessor architecture, alphanumeric backlit LCD display and real-time clock,
- 32 wireless and two wired parametric alarm zones with user defined names,
- identification of 16 users including 4 administrators with defining their names,
- arming and disarming of the panel by entering a password (3 to 6 digits access code) from the keypad, by the use of remote control transmitter,
- wide range of alarm zone types for specialized purposes,
- functional modes of partial arming of the control panel (day, night modes),
- panic and robbery alarm function (call for help) activated by remote control,
- operation with Elmes Electronic GSM module for remote arming, disarming, notification and monitoring and of alarm system using SMS and CLIP (*) calls,
- memory of the last 256 events, such as arming, disarming, alarms and power failures,
- acoustic signalling (beeps) of entry in a "chime type" zone,
- entry delay activated either by remote control, entering delayed zone or mobile phone,
- programmable "entry" and "exit" delay times in the range from 0 to 99 seconds,
- operation with WSS wireless external siren & strobe,
- wireless detector and external wireless siren presence monitoring,
- three wired alarm outputs with 1A fused overload protection and user defined signalling purpose (e.g. alarm, AC power failure, signalling or system arming), and programmable alarming time (0-999s),
- tamper sabotage protection for external signalling device wired to OUT1,
- radio jamming sabotage protection notified as alarm in zone 30,
- parametric (1 kOhm) input for TAMPER sabotage protection of external devices,

- RF monitor of signals received from detectors and interferences in the radio band,
- 92dB internal acoustic signalling device built-in under the keypad,
- mains powering by external unregulated power pack with 9-15VDC/150mA (panel alone) or 300mA (panel with GSM phone or module) minimum current output,
- up to 72 hours autonomy operation with two included AA size NiMH type rechargeable batteries (1800-2500mAh) on AC power supply failure,
- two front panel LED diodes for alarms, failures and arming indication & warning,
- easy panel configuration programming and firmware upgrade with the use of PC.

(*) CLIP - *Calling Line Identification Presentation*.

KEYPAD USE AND ARMING METHODS

Daily handling of the alarm system with the CB32 control panel involves arming and disarming of the system and checking possibly indicated alarm states. The control panel is operated with the use of keypad buttons described below:

- | | |
|----------------|--|
| 1,3,5,7,8,9,0 | -- numeric only buttons, |
| 2▲, ◀4, 6▶, 8▼ | -- numeric and menu selection cursor buttons, |
| C | -- cancel and menu exit button, |
| OK | -- selection acceptance & confirmation button. |

Current status of the system – date/time, arming mode of the control panel are displayed on the LCD while failure, alarm and arming information are indicated by two LEDs:

“**ALARM**” – lights on (red) at alarm detection and flashes indicating system failure. Alarm signalling is cancelled after entering the main menu or re-arming the system. Failure signalling is cancelled after eliminating its cause.

“**ARMED**” – lights on (green) when the system is armed, flashes when exit delay time is counted down.

The causes of alarms or system failures can be viewed upon entering main menu by holding down OK button and next selecting Alarm Memory or Failure Check submenu.

ARMING & DISARMING OF ALARM SYSTEM.

Arming and disarming of alarm system with CB32 panel may be done from the control panel keypad, by remote control transmitter (later referred to as a “remote”) or mobile phone SMS or CLIP. Disarming alarm stops alarming and silences alarm sirens.

1. Arming & disarming alarm from CB32 panel keypad.

There are two possible methods of arming and disarming using the keypad depending on the system “day/night” operation mode selection, see Service Settings (S.S.) pt. 8.7:

1. By entering user’s password followed by OK the system will arm if in disarmed state or disarm if in armed state (day/night mode is not selected “N” - pt. 8.7).

2. By entering user’s password followed by OK the system allows a choice of one of four supervision modes selected with “1”, “2”, “3”, “4” keypad buttons (day/night mode is selected “Y” – pt. 8.7.), as described further:

“**1 - disarm**” - disarming the alarm – “disarmed” status appears on display. “active 24h” anti-tamper zones remain armed.

“**2 - arm**” - arming the alarm. On end of the exit delay (signalled acoustically and optically with displayed time countdown on the LCD panel), all alarm zones are armed (*). “Armed” status appears on display.

- “3 - day” - partial arming of the alarm in day supervision mode. The zones earlier defined as “day armed” and the “active 24h” zones are armed (as in pt. 3.1). The “day mode” message appears on display.
- “4 - night” - partial arming the alarm in the night supervision mode. At the end of exit delay (signalled acoustically and optically) all alarm zones are armed (*), except for earlier defined as „night disabled” (as in pt. 3.1.). The “night armed” message appears on display.

(*) Permanently disabled zones are not armed in any of the above modes!

2. Operating Elmes Electronic CB32 panel using a remote.

The CB32 control panel can be remotely operated by the use of Elmes Electronic made remote control transmitters (e.g. one channel UMB100HT, two channels DWB100HT or four channels CH4HT) in two ways, as described below:

2.1 Arming and disarming the system.

One channel remote, e.g. UMB100HT. By pressing control button of one channel transmitter learned to CB32 panel would produce a single loud beep (*) and starts exit delay time. On end of the exit delay the alarm system is armed. Next pressing of the same control button would produce two loud beeps (*) and the system will disarm. If alarm occurred while in the system armed state, five loud beeps (*) would be produced on system disarming.

Two channels remote, e.g. DW100HT. Operation mode of the remote depends on settings made at pt 5.7.

Four channels remote, e.g. CH4HT. Button 1 (green) disarms alarm system, button 2 (red) arms, button 3 (blue) arms in night mode, button 4 (grey) arms in day mode.

2.2 Remote activates entry delay only.

This mode is possible if „Remote sets on delay” function is selected in S.S. pt. 8.1. Pressing remote button activates entry delay signalled by two loud beeps (*) and “remote delayed” zone type is disabled for as long as the entry delay time is set. While in entry delay, disarming of the system should be done by entering valid password from the keypad. Failure to disarm control panel and violation of “remote delayed” zone during entry delay will set up intruder alarm at the end of delay.

(*) Loud signal beeps can also be produced by an external siren wired to OUT1 (see pt. 9.4), then beeps from internal siren are at lower volume, or by wireless WSS siren (see pt. 9.5 of S.S.).

3. Arming & disarming using a mobile phone.

When GSM module is connected to Elmes Electronic CB32 control panel, alarm system can be armed and disarmed remotely from mobile phone using SMS command or CLIP call.

4. Arming the system bypassing selected alarm zones.

If, in the course of arming the system from control panel keypad, remote or mobile phone SMS or CLIP, one of the zones detects intrusion, the response of the system depends on whether the zone was earlier defined as “bypass” type (see item 3.1.g) and will be as follows:

- if the zone is defined as “bypass” type (Y) – the system generates 3 beeps and, if arming using keypad or remote transmitter only, prompts whether to arm the system without arming the intruded zone. Acceptance with the use panel OK button or remote button arms the system bypassing that zone. The use of any other button or no response (>8s) cancels arming procedure. Arming using mobile phone will arm the system and in return SMS will be received informing of the bypassed zone.
- if the zone is not defined as “bypass” type (N) – the control panel produces 3 beeps and displays message “Violated zones” with zone name and system will not arm. In that case, the cause of the zone violation should be cleared off and a new arming

should be made. While arming from mobile phone, the system will respond by sending SMS with information on violated zones.
See also S.S. pt. 9 – “System arming signalling modes”

CB32 SELECTED FUNCTIONS DESCRIPTION

Alarm detector monitor

Elmes Electronic CB32 control panel allows testing the operation of all wireless detectors installed in alarm zones by simultaneous display of their on/off status. To activate that function button “1” on the keypad must be pressed and hold down until two 16 points lines scale appear on the LCD panel. The displayed points represent all 32 wireless detectors that can operate with the CB32 control panel. Any detector activated in the system produces “*” mark to be momentarily displayed on the LCD at point position corresponding to alarm zone number to which the detector was learned. Tamper switch activation in the detector produces mark “S” to be displayed in the corresponding zone point on the scale. Exit from this function is made by next holding down button “1” of keypad.

Anti-sabotage of protection of external devices

Connecting TAMPER switches of external devices (e.g. phone dialler or siren) as shown on the diagram of Fig.2 enables anti-sabotage protection of these devices. Cutting off or shorting of the tamper wire generates sabotage alarm in zone 32 of the control panel. If the TAMP terminal is not used, it must be shorted to the GND terminal with 1kOhm resistor (supplied). The TAMP input terminal may be used to connect any parametric wired alarm detector to the CB32 control panel.

Operation with wired alarm detectors

Two parametric zones of the CB32 control panel allow connection of any wired alarm detectors with NC (normally closed) output terminals. Input EXT of the panel connects wired detector to alarm zone 31 while input TAMP may be used to connect wired detector to alarm zone 32. Detectors’ outputs wiring should be parametric configured using resistors (supplied) with one end wired to the GND terminal, as shown on fig. 1 of the manual. Wired detectors are recognized by the panel the same way as wireless detectors. Alarms are detected in the zone type selected by installer while sabotage protection is supervised as 24h type zone, permanently armed. Parametric resistors should be terminal connected inside wired detector’s housing. Powering of wired detectors is to be made from external AC/DC power pack of the panel. To ensure detector’s proper operation at AC power failure, power pack with integral battery backup may be optionally installed (buffered power pack).

IMPORTANT: Zones 31 and 32 of CB32 panel are factory set “disabled”. When wired detector is installed, the zone with wired detector must be enabled – see S.S. pt. 3.4.

Operation with remote control transmitter (remote)

The use of Elmes Electronic made remote to operate with CB32 control panel allows remote arming/disarming of alarm system as well as enables entry delay time for disarming from panel’s keypad. Also, panic alarm may be triggered using a remote. Detailed description of remote functions can be found in pt. 2 of Arming & Disarming of Alarm System section. Learning a remote to CB32 panel is made according to S.S. pt. 5.3. In addition, in “Auxiliary functions settings” menu pt. 8.1, a selection must be made as to whether the remote arms/disarms the system or sets on entry delay only. Also, in pt. 8.8 – a selection whether panic alarm is required or not and in pt. 9.4 and pt. 9.5 whether the use of a remote should be signalled on external siren.

Operation with external wireless siren

The CB32 wireless panel can operate with dedicated external wireless sound and strobe siren WSS that features integral transceiver module allowing periodical siren presence test. The siren is powered by external mains power pack (delivered with the siren) that recharges inter-

nal, not serviceable, sealed battery being siren's main source of power supply. The following steps are required to set WSS wireless siren operates with the CB32 control panel:

1. Learn the siren to alarm zone line 29 of the CB32 panel by selecting detector learning mode (see pt. 3.3) and activating the siren to transmit alarm signals in one of the three ways, as below:
 - a. Connecting siren's battery while mains power supply is off.
 - b. Connecting or disconnecting mains power while battery is connected.
 - c. Activating siren's housing top cover sabotage switch.
2. Set required alarming time at OUT1 of the panel that equals to alarming time of the wireless siren (pt. 6.4).
3. Set required time interval (1 to 99 minutes – 20 minutes as standard) between which wireless siren presence is tested (as described in S.S. pt. 6.5) and enable radio link testing (pt. 8.3).
4. Choose the way alarm system signals that radio link between wireless siren and the control panel is in fault. If the system is expected to set on loud alarm along with failure indication by LED, the function in pt. 8.11 should be set to ON. If only failure indication by LED is required then the function should be OFF.
5. If control panel is armed/disarmed from a remote (pt. 8.1), its use signalling on external siren can be set off (see pt. 9.4 and 9.5).

NOTICE! To avoid loud TAMPER alarm during maintenance service or installation when siren's housing is to be opened, temporarily disable alarm zone line 29.

Operation with Elmes Electronic GSM module.

If CB32 control panel operates with connected Elmes Electronic GSM module, the following features are available: remote arming and disarming of alarm system by SMS or CLIP call, alarm system status notification, remote disabling of alarm zones, SMS notifications to up to 8 mobile phones on alarms, arming/disarming, AC supply failure and return as well as system failures. Notifications include information of the source of the event. In case of intruder alarm and sabotage alarm, control panel makes also a CLIP call to registered phone numbers. It may also operate with any GSM mobile monitoring system by responding to its test signals and sending cyclic SMS notes or making CLIP calls.

Optional Elmes Electronic GSM module set includes battery and connection cable to communicate with CB32 panel and charge module's battery. With Elmes Electronic GSM connected, the CB32 current draw increases by 200 mA (see specification).

CB32 panel configuration and firmware upgrade using PC

Starting from version 3.00 of firmware, the CB32 control panel can be easily configured and firmware upgraded with the use of Windows® based PC (Personal Computer). To connect the panel to PC a dedicated USB-RS interface cable is needed (ordered separately). Also, installation of virtual COM port drivers at the PC are necessary. The drivers as well as dedicated "CB32 Configurator" configuration software are free for download from the panel manufacturer web site: www.elmes.pl.

Before any data is send to or received from the CB32 panel, the following installation steps should be followed:

1. Select serial COM port that appears new in "CB32 Configurator" options after connecting the USB-RS interface cable to PC.
2. By holding down button "2" of the panel's keypad at power on, force the panel to set up communication mode with PC. Displayed flashing "?" sign on panel's LCD confirms the mode has been entered.

MAIN MENU

To access the main menu of the CB32 panel press and hold down OK button for more than two seconds. Navigate the menu using vertical and horizontal cursor keys. If the keypad is not used for more than two minutes the menu exits and display of the current status of the control panel on the LCD panel returns.

Alarm Event Memory

In this menu details of the latest alarm events are displayed: date, time and zone of the alarm(s) source. The use of ▲▼ keys selects earlier or later events respectively, while the use of ◀▶ buttons selects between alarm type and alarm source, e.g. "Intruder alarm" ↔ "kitchen".

Failure Check

This menu is designed to view the causes of the failures signalled on the control panel by flashing "ALARM" LED. Failures signalled on the control panel include:

- Mains power supply failure.
- Rechargeable battery absence or failure.
- Communication errors with wireless detectors or siren.
- Detector's low battery.
- Communication error with GSM module.

▲▼ keys are used to scroll through failures.

The "ALARM" LED stops flashing when the cause of failure is cleared.

Service Settings (S.S.)

Access to Service Settings menu is enabled only if the control panel is disarmed and upon entering a valid password code confirmed by OK button. Factory setting of the password for the user No.1 is „0000". Exit from the menu and cancelling entries are made by the C button. Users Nos. 1-4 (administrators) have access to all functions whereas other users may access functions 1-2 only. All editable service settings available in this menu are described further.

1. Event Memory

Service settings → Event memory

This menu allows viewing detailed information on last 256 events that occurred in the system (alarms, failures, arming, disarming, errors, etc.). Event memory cannot be edited, and allows only viewing the event details in the sequence of their occurring date and time. Buttons ▲▼ select an earlier or later event while ◀▶ buttons select between type of event and its source, e.g. "Arming" ↔ "John".

2. Password Change

Service settings → Password change

This menu allows changing user's own password. Password of other users can be changed in the "Users" menu (see pt. 5). After accessing this menu "Enter password" prompt appears. Enter new password containing 3 to 6 digits, and then press OK. When the "Repeat password" prompt appears, enter the new password again and press OK. The new password replaces old one. In case of entering an existing or incorrect password "Wrong password" message appears.

3. Zone Settings

This menu contains several submenus. Entering any submenu with ▲▼ buttons selects zones while ◀▶ buttons select between zone number or zone name, e.g. "Zone no 1" ↔ "Kitchen".

3.1. Assigning functions to alarm zones.

Service Settings → Zone settings → Zone function

In this menu Elmes Electronic CB32 control panel allows assigning functions to alarm zones. Buttons ▲▼ select one of the functions described below while ◀▶ buttons allow setting the function ON (Y) or OFF (N). The use of OK button accepts the selection while the use of C button cancels changes and exits the menu without saving changes.

- | | |
|---------------------|--|
| a) "24h" | - 24 hour zone, e.g. anti-sabotage zone (permanently armed), |
| b) "day armed" | - zone armed in day supervision mode selection, |
| c) "night disabled" | - zone disabled in night supervision mode, |
| d) "remote delayed" | - zone with entry delay set on by remote control transmitter, |
| e) "delayed" | - standard entry zone with delayed alarming, |
| f) "chime" | - zone with door chime beep feature on zone violation, |
| g) "bypass" | - zone that can be left disarmed if violated on system arming. |

A standard zone has functions a).c) set off in armed state mode, when the system is "armed" or in "night armed" mode and disarmed when the system is "disarmed" or in "day armed" mode. **IMPORTANT:** Zones can have assigned more than one function, but some functions exclude others. In that case, only one selection is valid, e.g.:

- if a zone is "active 24h" then functions such as "day armed", "night delayed", "delayed", and "bypass" have no meaning;
- if a zone is delayed, it should not be disabled by remote.

Examples of assigning functions to alarm zones:

- Entry zone can be "remote delayed", i.e. after using remote button entry delay countdown is started. Security violation in the zone during the countdown will not generate the alarm immediately, but after the countdown is finished. That allows user sufficient time for safe disarming the system.
- Entry zone can also be a delayed zone, i.e. when the zone is violated, the entry delay countdown starts and the system must be disarmed before the countdown is finished. If system is not disarmed an audible alarming sets on.
- The "chime type" zone which often is also a "delayed" or "remote delayed" zone, generates two beeps sound signal on every violation of the zone (e.g. notifying customer entrance to a store).
- A basement zone can be "day armed" but it cannot be "active 24h" simultaneously.
- A „bypass" zone type allows arming the alarm while intentionally leaving a window opened protected by CTX3H or CTX4H detector (see "System Arming").

3.2. Zone name.

Service settings → Zone settings → Zone name

This menu allows alarm zones used in the system to have user defined up to 16-character name, e.g.: kitchen, living room, office, Mark's Room, etc. Uppercase and lowercase letters, digits and the following characters are accepted: space, "-", ".".

Buttons ◀▶ select the successive letters of the name while the ▲▼ buttons browse character table. Accept name with OK button. Use C button to exit the menu.

3.3. Learning wireless detectors.

Service settings → Zone settings → Learning detectors

In this menu use the ▲▼ buttons to select zone number, and the ◀▶ buttons to toggle between displaying the zone number and zone name, e.g.: zone 1 ↔ kitchen. OK button accepts all selections. If detector is already learned to selected zone, "OK-remove" prompt appears. Pressing OK button deletes detector in the zone. If zone is vacant, the "OK-learn" will appear on the LCD. Pressing OK button starts learning detector to the zone. In response to the

“Awaiting trans. 1” and “Awaiting trans. 2” prompts, two successive alarm transmissions must be triggered from detector (*). Correct learning will be followed by “OK-correct” message. Errors are signalled by 3 beeps and “Program error” message. The use of C button exits the menu.

(*) For detailed information on how to learn particular Elmes Electronic detector to CB32 control panel please refer to instruction manual of the detector.

3.4. Zone disabling.

Service settings → Zone settings → Zone disabling

Buttons ◀▶ disable and enable zone selected with ▲▼ buttons. Accept selection with OK button. Exit the menu with C button.

3.5. Radio range test.

Service settings → Zone settings → RF range test

To assess the level of radio reception of signals received from detectors, the most distant detectors in particular, the CB32 panel is provided with “RF range test” function allowing the received signal level to be displayed on 16-point bar graph scale of LCD.

After entering this menu all RF signals in the 433.92MHz radio band will be displayed in form of bar graph. The detectors should be triggered to send alarm transmissions. The longer the distance of the detector from the control panel, or the greater difficulty in radio waves propagation, the lower the level of received signals and the length of the displayed bar graph. If the number of displayed fields is lower than three it should be assumed that this connection does not guarantee reliable alarming. The location of detectors or the control panel should be changed in search for better connection quality. The “RF range test” function allows also assessing levels of all local RF signals in the 433.92MHz band, also those that can interfere and disturb operation of the wireless alarm system. The test should be carried out prior to permanent installation of alarm devices or, in search for causes of short operation range. To find out any interfering signals, the LCD bar graph 16-point scale readouts should be observed without activation of own detectors. Frequent or continuous unknown RF signals received and signalled on the control panel display indicate close presence of other RF devices operating in the same RF band. If level of these signals exceeds three fields displayed in the “RF range test” function and their occurrence is frequent, acceptable signals from detectors may not be received and the alarm system may fail to operate properly.

4. Outputs settings.

Service Settings → Outputs settings

In this menu intended use of wired outputs of the control panel can be defined. All three outputs of the panel are OC type and connect to ground in active state. Output OUT1 is designed exclusively for connecting external signalling device and can be sabotage protected (see S.S. pt. 8.4). In addition, this output can be configured to signal the use of a remote. The use of wired outputs OUT 2-3 could have the following designation:

- “**alarming**” - for connection of outdoor/external alarm signalling devices, e.g. external siren or/and strobe. Alarming time can be set within 0-999 seconds range separately for each output (see pt. 6.4);
- “**AC power failure**” - signalling AC power supply failure/cut off;
- “**arming**” - signalling on system armed or night armed and inactive on system disarmed or in day armed mode;
- “**failure**” - signalling any failure state in system (also AC power failure).

Example: if “**arm/disarm**” signalling mode is selected at OUT 2 and the output is connected to powered external LED, lamp, etc., it will switch on the device for as long as system is armed warning of the security system being in supervision state. The “**arm/disarm**” mode

can also be used for remote control. For example, operated with Elmes Electronic ST100HGR controller it may control opening/closing of window rollers. Signalling mode at OUT 2-3 are set by accessing the menu, selecting output number with ▲▼ buttons, accepting with OK, then selecting signalling type with ▲▼ or ◀▶ buttons and accepting with OK button.

5. System users - adding, editing and removing a user.

Service Settings → System Users

This menu contains several submenus. Entering any submenu with ▲▼ buttons selects system user number while ◀▶ buttons select between user number or user name, e.g. "User no 1" ↔ "John Dutch". Accept user selection with OK button and pass on to submenu:

5.1 Setting and edition of user password.

Service Settings → System Users → Password

Please follow detailed instructions in "Password Change" menu (pt. 1 of S.S.).

To delete user's password press OK button when "Enter password" prompt appears. On next prompt "OK-delete password" again press OK button. "Password deleted" message confirms password is deleted.

5.2 User name change.

Service Settings → System Users → Name

Please follow detailed instructions as in "Zone name" menu (pt. 3.2 of S.S.)

5.3 Remote learning and deleting.

Service Settings → System Users → Learning a remote

In this menu user's remote is learned or deleted. Please follow detailed instructions in "Learning detectors" menu (pt. 3.3 of S.S.).

5.4 Disabling of user.

Service Settings → System Users → Disabling user

Please follow detailed instructions as in "Zone disabling" menu (pt. 3.4 of S.S.). After disabling a user, its remote and password are inactive. In order to disable user's control of CB32 panel by SMS or CLIP, the functions should be set off at pt. 5.6.9 and 5.6.10.

5.5 Mobile phone number.

Service Settings → System Users → Phone number

This menu allows entering user's mobile phone number. The number must be preceded by national dialling code number, without the "+" sign. Example: 33xxxxxxxx for France.

5.6 Mobile phone functions.

Service Settings → System Users → Phone functions

This menu allows selection (Y/N) of notifications, messages, commends and SMS/CLIP functions required active in user's GSM phone operating with CB32 control panel.

- 1) SMS on alarm - sending SMS on alarm set on;
- 2) SMS on arming - sending SMS on arming and disarming of system;
- 3) SMS on powering - sending SMS on mains power failure and return;
- 4) SMS on radio link off - sending SMS on radio link failure;
- 5) SMS on low battery - sending SMS on low battery;
- 6) SMS on other failures - sending SMS on other failures (e.g. accumulator failure);
- 7) Alarm CLIP - making alarm CLIP call;
- 8) Descriptive SMS <-> SMS with ID codes - selection of SMS content: event description such as "Intruder Alarm" or two character ID codes defined in pt. 7.9.

- 9) **SMS accept** - SMS commands (as below) acceptance received by CB32.
 ARM, DISARM, NIGHT and DAY- sets appropriate arming mode;
 DISABLE zone_name - disables zone: zone_name;
 ENABLE zone_name - enable zone: zone_name;
 STATUS - in response control panel sends SMS on current armed/disarmed status and failure events;
 TIME HH:MM - sets time in control panel;
 TEST - sets up instant test procedure and starts time count to next test under condition that "Test every time interval" is selected in pt. 7.10.2 and "Execute test" function is selected in pt. 5.6.12.
- 10) **CLIP arming** - remotely CB32 panel arming and disarming by CLIP call. Panel is disarmed if call is rejected after one ring. If the call is rejected after three rings, the panel is armed.
- 11) **Call back** - calling back function. If the control panel is called, it will call back. This and next function may be used in operation with monitoring center:
 - if the function is set on, GSM monitoring center calls to CB32 and the panel rejects the call after 3-4 seconds,
 - if the function is set off, the control panel calls back the monitoring center after rejecting incoming call.
- 12) **Execute test** - executing SMS or CLIP time interval test by CB32 panel. The function may be used in operation with monitoring center. See also pts. 7.6, 7.7, 7.10 of System users section.

5.7 Remote type and mode of operation.

Service Settings → **System Users** → **Remote type**

This menu allows selection of remote's operation modes. Description: 1CH-one channel remote, 2CH-two channels remote, 4CH-four channels remote.

1CH: arm/disarm - any selected button alternatively arms and disarms control panel. Remaining buttons, of e.g. 4-channels remote, may be used for other remote control purposes.

2CH: arm/disarm, night/disarm - button 1 (green) of 2-channels remote (*) arms and disarms control panel alternatively while button 2 (red) arms in night mode and disarms the panel.

2CH: disarm, arm - button 1 (green) of 2-channels remote (*) disarms while button 2 (red) night arms the panel.

This mode allows real time clock channel of Elmes Electronic STX remote to arm/disarm control panel automatically, at predefined times.

2CH: disarm, night arm - button 1 (green) of 2-channels remote disarms while button 2 (red) arms in night mode.

4CH: disarm, arm, night, day arm - button 1 (green) disarms system, button 2 (red) arms, button 3 (blue) night arms, button 4 (grey) day arms.

(*) In this mode a 4-channel remote can also be used. Button 1 is then meant as the first of 1-2 or 3-4 buttons pairs.

NOTE: Users 1..4 are system administrators with unlimited access to all service functions, whereas other users have access to Service Settings functions 1 and 2 and are allowed to change their password and review CB32 event memory only.

6. System times settings.

6.1. System date/time setting.

Service Settings → Times settings → System date/time

This menu allows setting system date and time. The ▲▼ and ◀▶ buttons are used to select current date and time and the use of the OK button accept the selection. Exit the menu with C button.

6.2. Entry delay time (0..99s).

Service Settings → Times settings → Entry delay

This menu allows setting the alarm activation delay time (in seconds: 0 to 99) needed to enter the premises and disarm alarm system from the CB32 keypad. Two digits on the right side of the display show available entry delay time in seconds. The required time is set with the use of cursor buttons and accepted with the OK button.

6.3. Exit delay time (0..99s)

Service Settings → Times settings → Exit delay

This menu allows setting time delay needed to exit premises (in seconds: 0-99) after alarm system arming from the CB32 keypad. Two digits on the right side of the display show available exit delay time in seconds. The required delay time is set with the use of cursor buttons and is accepted with the OK button.

6.4. Alarm duration timing at outputs 1 to 3 (0..999s).

Service Settings → Times settings → Alarm duration OUTx where x=1, 2 or 3.

This menu allows setting alarm duration timing (in seconds: 0 to 999) on outputs OUT1..3 individually. Three digits on the right side of the display specify current alarm duration in seconds of selected output. The required time is set with the use of cursor buttons and is accepted with the OK button. Alarm duration of OUT1, the built-in siren and wireless WSS siren are the same. Timing set for outputs function other than alarming has no meaning for their operation.

6.5. Wireless siren check up interval (1..99 minutes).

Service Settings → Times settings → WSS siren check-up interval

This menu allows setting time interval between checking of WSS wireless siren presence (in minutes: 1 to 99) - as standard set to 10 minutes. The required interval time is selected by the use of cursor buttons and accepted by OK button.

6.6. Control panel clock run adjustment.

Service Settings → Times settings → Clock adjustment

This menu allows adjustment of control panel clock fast/slow run within -99 to +99 steps range. Decreasing steps slow the clock while increasing steps speed up clock. One adjustment step equals 0,0864 second fast/slow run per day (24h).

7. Alarm notification by Elmes Electronic GSM module.

This menu defines required settings for alarms and other notifications send by GSM module connected to CB32 panel.

7.1 SMS center phone number.

Service Settings → GSM monitoring → SMS Center number

This menu is used to enter the phone number of GSM operator's SMS center, preceded by country code dialling without "+" mark in front. This is important if "Use entered SMS center no" selection is made in menu pt. 7.10.6. Example: the following phone number should be entered for Plus GSM operator in Poland: 48601000310

7.2 Alarm & arming SMS notifications daily limit (24h).

Service Settings → GSM monitoring → Alarm SMS daily limit

Feature allowing limitation of daily SMS notifications send by CB32 control panel on system alarm, arming and disarming. Limit is factory set to 99 and resets daily at 12:00 hours.

7.3 System failure SMS notifications daily limit (24h).

Service Settings → GSM monitoring → Failure SMS daily limit

Feature allowing limitation of daily SMS notifications on system failures send by CB32 control panel and registered in event memory. Failures are divided into three categories. First category includes "Mains power failure", "Accumulator failure" and "System restart", second "Radio link failure" and third "Low battery" failure. SMS notification limit is factory set to 10 in each category and resets daily at 12:00 hours. Change of factory limit (10) results in limit change in all categories and CB32 event memory.

7.4 Calling duration.

Service Settings → GSM monitoring → Calling duration

This feature defines duration of CB32 alarm notification CLIP calling. It should be set to time value allowing user to reject call before the time lapse if function "Alarm CLIP once" (pt. 7.10.5) is set off. See also pt. 5 of FAQ section of manual.

7.5 SMS password.

Service Settings → GSM monitoring → SMS password

This menu is used to enter a maximum 6-character password that will precede SMS command text if option "SMS with password" is selected at pt. 7.10.3.

7.6 Test SMS.

Service Settings → GSM monitoring → Test SMS

This menu is used to enter Test SMS content send by GSM module when test function is set on at pt. 5.6.12 and "Test as SMS" option is selected at pt. 7.10.1.

7.7 Test interval/Test time.

Service Settings → GSM monitoring → Interval/Test time

This menu is used to enter time interval (if option "Test interval" is selected at pt. 7.10.2) or, test time (if option "Test time" is selected at pt. 7.10.2) when the CB32 control panel is expected to perform SMS or CLIP test. Maximum value is 24h. This feature is valid only if "Execute test" option is selected at pt. 5.6.12.

7.8 Selection of GSM module/phone to operate with CB32.

Service Settings → GSM monitoring → Mobile phone type

This menu is used to select optional model of GSM module or mobile phone that may be connected to and operated with CB32 control panel. Currently, only Elmes Electronic GSM module (ordered separately) is hardware/software ready to operate correctly.

Confirm option "Elmes Electroni GSM" with OK button when it appears on display. Required for connection cable interface is included with GSM module.

7.9 Definition of SMS notification ID codes.

Service Settings → GSM monitoring → SMS ID codes

This menu is used to enter two character ID codes send in SMS event notifications. Each code contains two characters (ASCII codes in range 32 to 90 decimal), e.g. some symbols, digits and uppercase English alphabet characters. To set the CB32 panel to send ID codes instead of standard text notification, e.g. "Intruder alarm: kitchen", option "SMS with ID codes" must be selected at pt. 5.6.8.

7.10 Auxiliary GSM notification settings.

Service Settings → GSM monitoring → Aux GSM settings

- 1) Test as CLIP <-> Test as SMS - interval test as CLIP call or SMS;
- 2) Execute test at time <-> Execute test after interval - test executed daily at predefined test time, or test after predefined time interval;
- 3) SMS with password - if Y (yes), SMS send to CB32 must begin with password;
- 4) Letter case sensitive - N (no) as standard. If selected Y (yes), the control panel is SMS letters case sensitive;
- 5) Alarm CLIP once - if this function is set off (N), control panel expects CLIP notification rejection. If the call (see pt. 7.4) is not rejected, the panel disconnects and repeats CLIP call twice. If the function is set on (Y), CLIP calling is made once only, even the call was not rejected. It does not refer to a control CLIP that is made only once;
- 6) Use default SMS center no <-> Use entered SMS center no - selection of the first option allows CB32 panel to use SMS center number supplied with SIM card, while selection of the second option causes CB32 to use center number entered at pt. 7.1.

8. Auxiliary functions settings.

This menu contains auxiliary functions and options for alarm system configuration available in the CB32 control panel. Use ▲ ▼ to toggle between functions and ◀ ▶ buttons to change setting. OK button saves selection. Exit menu any time with C button without saving selection.

8.1 Arming & disarming alarm system with remote.

Service Settings → Aux functions → Remote arm/disarm / Remote sets on delay

This menu allows user to select remote/s operating mode. Remote may arm, disarm alarm system or set on time delay in zones type "remote delayed", see pt. 3.1.d.

8.2 Radio jamming protection.

Service Settings → Aux functions → Jamming protection

This function allows radio jamming anti-sabotage protection of wireless alarm system. If selected (Y), it will activate sabotage alarm in zone 30 on all deliberate or incidental jamming in used radio band.

8.3 Radio link test.

Service Settings → Aux functions → Radio link test

Setting this function to (Y) enables monitoring of the detector presence. Radio link transmissions are sent at cyclic intervals from detectors (except for CTX3H) received by CB32 control panel. If, for any reason, radio link transmission from a detector is not received during 24 hours, "radio link failure" will be indicated by flashing "ALARM" LED in the panel.

8.4 Anti-sabotage protection test of output 1.

Service Settings → Aux functions → Out1 Test

The OUT1 output, which is by default used for connecting an external signalling device, is provided with anti-sabotage (Tamper) protection against wires cutting off or shorting to

ground. After accessing this menu the user can turn this protection on or off. Damage, cutting off or shorting wires connecting this output with external signalling device - is indicated by sabotage alarm in zone 32.

8.5 Internal siren alarming.

Service Settings → Aux functions → Internal siren

This option allows setting on/off alarm signalling by control panel internal siren.

8.6 Signalling accumulator absence or failure.

Service Settings → Aux functions → Accu failure

This option allows setting on/off CB32 internal accumulator failure signalling, recommended to be set to off (N) when rechargeable batteries are not used.

8.7 Activating selection of day & night arming modes.

Service Settings → Aux functions → Day/night mode

Activating the function (Y) will display additional menu on LCD allowing selection of supervision modes confirmed by password and the OK button. There are 4 modes available: 1 - disarmed, 2 - armed, 3 - day, 4 - night (see also: "Arming/disarming alarm system"). With the function set off (N), the menu is not displayed and entire alarm system can be armed and disarmed from control panel keypad by password followed by OK. Partial night mode and day mode arming would not be available to set on from keypad. However, night mode arming is still possible if arming is made by the use of a remote (see details pt. 5.7).

8.8 Panic alarm (call for help) function.

Service Settings → Aux functions → Panic alarm

Setting this function on (Y) allows panic alarm for users equipped with remote control. The alarm is activated when remote button is pressed for longer than 2 seconds and alarm lasts for as long as the alarming time set on the OUT1. Control panel registers the event as panic alarm and user's name. With GSM module connected, an appropriate SMS notification is sent. Setting the alarm OFF is done by entering a password from keypad or by the use of remote control if "Remote arming/disarming" function (pt. 8.1) is set on.

8.9 Control panel beeps on/off.

Service Settings → Aux functions → Keypad beep

This option allows setting on/off all control panel beep signals except for signalling an intruder alarm that can be set off at pt. 8.5.

8.10 Beeps on entry delay count on/off.

Service Settings → Aux functions → Entry delay countdown beep

This option allows setting on/off entry delay countdown beep signals in addition to countdown display on control panel LCD.

8.11 Alarm on radio link with WSS siren failure.

Service Settings → Aux functions → WSS siren link alarm

Setting this function to yes (Y) allows loud alarm along with LED alarm notification on wireless Elmes Electronic WSS siren radio link check-up test failure. As standard the function is set to no (N) and the failure is signalled by flashing Alarm LED only. Failure check menu will display "Radio link error" and name of zone 29 (if specified).

8.12 Limitation of alarms from one alarm zone.

Service Settings → Aux functions → Alarms limit to 3

This function limits number of alarms in one zone to three and is factory set to on (Y). Alarms count is reset on every arming or disarming of the system. When the limit is selected to off (N) alarm sets on every violation is detected in the alarm zone.

8.13 Selection of menu language: Polish/English.

Service Settings → **Aux functions** → **Język polski** / **English language**

This function allows selection of panel's menu language: English or Polish.

NOTE! Change of menu language is also made with button "1" of the keypad hold down while connecting power supply to the panel.

8.14 Backlight modes of LCD panel and keypad.

Service Settings → **Aux functions** → **Permanent backlight**

Setting this function to yes (Y) selects permanent backlight of LCD panel and the keypad. As standard the function is set to no (N), meaning the LCD panel and the keypad are backlit upon any key on the keypad is pressed. Backlight sets off within 40 seconds of last key pressed.

9. System arming signalling modes.

Service Settings → **Arming signalling modes**

This menu allows selection of alarm system arming and disarming signalling modes. Use ▲ ▼ keys to toggle between functions and ◀ ▶ keys to change setting. OK button saves selection. Exit menu any time with C button without saving selection.

9.1. **Remote: pulses** ↔ **Remote: pulses + SMS if problem** – selecting the first option sets on signal pulses on sirens only. Selecting second option allows pulses on sirens and SMS notification if any problem occurs (*).

9.2. **SMS: SMS** ↔ **SMS: pulses + SMS if problem** – selecting first option a return SMS is send on SMS arming. Selecting second option sets on pulses only and SMS notification is received only if problem occurs (*).

9.3. **CLIP: SMS** ↔ **CLIP: pulses + SMS if problem** – selecting first option a return SMS is send on CLIP arming. Selecting second option sets on pulses only and SMS notification is received only if problem occurs (*).

9.4. **Loud internal pulses** ↔ **Pulses on OUT1+quiet internal** – selecting first option sets on arming pulses on internal siren only. Selecting second option sets on pulses on external siren connected to OUT1 along with quieter pulses signalled on internal siren.

9.5 **Pulses on WSS** - setting on arming signalling pulses on wireless Elmes Electronic WSS siren.

(*) While system arming violation of a zone may occur. Depending on whether the zone is "bypass" type (see pt. 3.1.g), the system will arm and SMS notification will be send informing of the bypassed zone/s or, if the zone is not "bypass" type, the system will not arm and SMS notification will be send with information of violated zone/s.

10. System Status

10.1 **Service Settings** → **Status** → **GSM signal level**

Horizontal bar graph display of mobile signal strength as received by Elmes Electronic GSM module connected to CB32 control panel. Strength level weaker than indicated by four bars only is insufficient and either control panel/GSM module placement should be changed or external coaxial cable GSM antenna connected.

10.2 **Service Settings** → **Status** → **Elmes Electronic CB32 ver. X.XX**

Displays installed firmware version of CB32 control panel.

SETTINGS RESET

Resetting password of user number 1.

If user no 1 is disabled or its password is lost and there is no way to enter Service Settings menu of the control panel, it can be hardware enabled and have factory password "0000" restored, in the following way:

1. Open the panel's cabinet (sabotage alarm may occur), disconnect AC power and remove batteries.
2. Short circuit two RESET points (in the upper left corner of the pc board).
3. Connect power supply or insert batteries and next disconnect shorted RESET points.

User no 1 is now enabled and its password is restored to "0000", zones 31 and 32 are disabled and anti-sabotage protection control of OUT1 set off. All other settings remain unchanged.

CB32 restore to factory settings (default settings).

Factory (default) settings are restored according to procedure described below. The procedure restores factory settings deleting all wireless devices in memory. Records in the event memory are not deleted.

1. Open the panel's cabinet (sabotage alarm may occur), disconnect AC power and remove batteries.
2. Short circuit two RESET points (in the upper left corner of the pc board).
3. While holding down button 3 of the keypad connect power supply – display will show notification: "Factory settings".
4. Release button 3 and wait until control panel restores normal operation.
5. Disconnect shorted RESET points.

DESIGNING WIRELESS ALARM SYSTEM

Designing and installation of alarm system with the Elmes Electronic CB32 control panel should begin with careful planning of detectors, control panel and outdoor siren place of installation arrangement. To ensure satisfactory protection of secured premises a variety of detectors may be needed. Elmes Electronic PTX50 wireless motion detector and CTX3H or CTX4H wireless magnet contact detectors should be installed in each protected room with window. Additionally, Elmes Electronic GBX1 wireless glass break detector could be installed for protection of windows breakage in premises and shops. Depending on needs one or two wired detectors can be connected to parametric EXT and TAMP inputs of the panel. The panel will also operate with RP501 four channel transmitter offering one to four wired detection inputs to be monitored remotely. Learning the RP501 transmitter to the CB32 control panel by activation of input no 4 will learn all four transmitter's inputs to four adjacent alarm zones of the panel. Activating input four of the RP501 while learning the transmitter to zone 20 of the panel will assign four RP inputs to alarm zones no 17, 18, 19 and 20. When installing detectors and RP501 transmitter respective instruction manuals must be followed.

It is highly recommended that before permanent installation of detectors or control panel operating range tests should be taken to confirm reliable communication of the devices with the CB32 panel. The RF range test allows evaluation of operation range of wireless devices. This function available in Service Settings menu (pt. 3.5) and may also be helpful in detecting any interfering radio signals. If signals received by the control panel are weak, there may be a need to relocate installation places of some detectors or the control panel. In extreme cases, it is recommended that Elmes Electronic TRX transceiver signal repeater to be used to ensure proper performance of the alarm system.

Installation place of detectors is determined individually. Access to the control panel should meet specific needs of protected premises but it is not recommended to place the panel next to the door or in place easily accessible. Best suggested way of disarming the alarm system is to activate entry delay from outside of the premises with the use of a remote. It allows safe

opening the entrance door, access control panel keypad to disarm the system with password. The entry delay programmed by an installer or user should allow convenient access to the control panel keypad.

The CB32 control panel may also be installed in place such as bedroom or study room, allowing complete elimination of the entry/exit delay time. In that case, arming and disarming of the alarm system from the outside of premises can be made with the use of a remote or mobile phone, if GSM module is installed with the CB32 control panel. Arming and disarming will be audibly signalled by siren or lamp connected to an output configured to arming and disarming signalling.

The panel features also the option of arming alarm system in the night mode with selected rooms excluded from supervision (e.g. bedrooms, upper floor), as well as the day mode in which only the selected rooms (e.g. cellar, basement, garage) are supervised. Arming entire alarm system, or in night/day modes is done with the use of the CB32 panel keypad. Arming entire system or arming in the night mode only is also possible with the use of remote. All options and functions of alarm system designed with CB32 control panel are user selected and set in the Service Settings menu of the panel.

POWER SUPPLY SOLUTIONS

To ensure proper operation the CB32 control panel requires external 230VAC/12VDC regulated or unregulated (9...20VDC) power supply pack with minimal current output ranging from 250mA (panel alone) to 350mA (panel with Elmes Electronic GSM module operated).

Initial powering of the panel starts with screwing in DC output wires of the AC/DC power pack to +/- terminals of the panel. Plugging the pack to AC outlet backlights the LCD panel and displays software version followed by initial date (day_month), time (hour: minute: seconds) and status: "disarmed". Flashing "ALARM" LED signals batteries absence. Next, two AA size NiMH type rechargeable batteries could be installed observing correct polarity (+/-) marked in their compartments. After initial charging "ALARM" LED stops flashing.

IMPORTANT! Use **AA** size **NiMH** type **rechargeable batteries** only with recommended capacity of 1800 to 2500mAh. The use of other than NiMH batteries with AC power supply pack connected (battery charging) **is not permitted** and may cause damage.

The use of batteries with lower capacity than recommended could not guarantee 72 hours of emergency AC power cut off operation. After initial 25-30 hours of panel operation (batteries first charging) the power pack should be disconnected, and the batteries discharged by powering the panel from the batteries only. Discharged batteries will be recognized by the LCD panel cease to display any message. The AC power pack should be mains plugged again to restore panel operation and recharge the batteries. This battery forming operation retains maximum capacity of the batteries.

<p>CAUTION! Batteries may contain poisonous substances. Do not dispose of waste batteries with household waste. Dispose of waste batteries according to your local recommendations.</p>
--

Operating CB32 with wired alarm system and system backup power supply the panel may be powered from 13,6 VDC auxiliary supply line voltage dedicated to power detectors, sirens, etc.

NOTICE! Manufacturer supplies control panel with zone 31 EXT and zone 32 TAMP disabled and anti-sabotage control of output OUT1 set off allowing connection of external siren and power supply to the CB32 panel without activating sabotage alarm. After completing system connections, inserting the batteries and closing panel case, the anti-sabotage protection should be enabled.

ALARM SYSTEM WITH ELMES ELECTRONIC CB32 CONTROL PANEL

Designed alarm system may be less or more complex depending on individual needs. Simplest alarm may consist of only few detectors and the control panel with internal siren for audible signalling, while complex alarm system would have a range of detectors in addition to internal and external signalling devices and GSM phone notification.

The diagram presented on the next page shows an example of a complex alarm system with the use of PTX50 wireless motion detectors, Elmes Electronic CTX3H and CTX4H magnet contact (open & close signalling function) detectors, GBX glass break detector, Elmes UBM100H remote control for activating entry delay and panic alarm, wired external siren, phone dialler or GSM phone and CB32 control panel. The system should be power supplied from a dedicated buffered power pack with integral battery backup. Other advisory examples of alarm configurations based on Elmes Electronic CB32 wireless control panel are presented on Fig.1 and Fig.2.

Wiring of external equipment such as sirens, AC power supply or phone dialler to the CB32 control panel terminals, should be made through large installation whole and a cable groove in the bottom part of the cabinet. Suggested installation of the control panel is in vertical position, e.g. on the wall at the height of approx. 1.20 to 1.40m, allowing convenient entering keypad commands. The configuration procedure for an exemplary alarm system described further assumes that the user will use a remote control to activate the entry delay. It is recommended to make basic settings, learn detectors and carry out the first tests on workshop table before permanent installation in the rooms. Following are some basic essential steps to be taken at first wireless alarm system configuration setting:

Unpack the CB32 control panel; **first connect** AC/DC power pack **and then** insert rechargeable batteries observing polarity (+/-) marked inside the panel cabinet.

1. Enter Service Settings menu by pressing and holding down OK button (initial password: 0000), and input current date and time (pt. 6.1). Enter new password (pt. 5.1), the name of the first user and learn remote control transmitter to the user.
2. Unpack wireless detectors: PTX50 (motion), CTX3H or CTX4H magnet contacts (opening/closing) and GBX1 (glass break), install batteries and configure according to the included manuals and requirements of the alarm system. Install wired siren or learn dedicated Elmes Electronic WSS outdoor wireless siren to CB32 panel.
3. Learn detectors to alarm zones of the panel (item 3.3) and test their operation with the "Monitor of Alarm Detectors" function of the CB32 control panel (see page 5).
4. Set the zone with the entry detector as a „remote delayed" zone (item 3.1.d of S.S.).
5. Set the entry delay time (item 6.2) according to individual requirements.

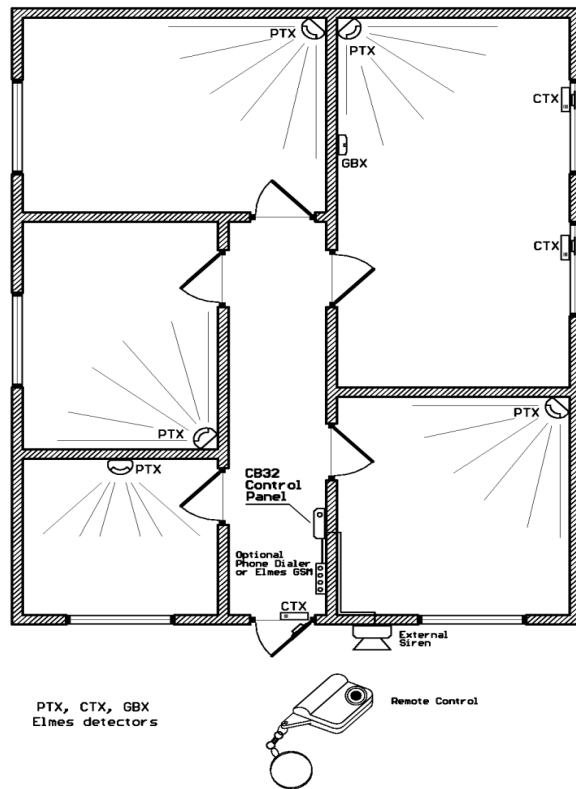

The above steps allow first workshop tests of the constructed alarm system. The CB32 panel's internal siren will audibly signal all alarms and arming/disarming commands. After initial testing the control panel and detectors could be installed in selected places, while checking for the level of the radio signals received from each detector by the control panel ("RF range test"- item 3.5 of S.S.). Other person help may be needed to activate detectors while the signal level readouts are watched and evaluated.

To enable the anti-sabotage protection against detaching the control panel from wall, the square piece of the backside plastic over the Tamper switch should be removed.

With the system installed and tested in basic configuration, other devices such as an outdoor siren/strobe device, phone dialler or a GSM phone can be added. Also, some other functions of the CB32 panel such as anti-sabotage of the OUT1 output (item 8.4), disable signalling on the internal siren (item 8.5) or the RF link test between detectors and the control panel, can be defined and set. New users with names (item 5) can be added as well as names of alarm zones can be defined (item 3.2)

WIRING DIAGRAMS

In a sample installation in Fig. 2, an external wired siren, phone dialler, GSM phone and a buffered power pack (Z1) ensuring operation of the system at AC power failure are used. The power pack supplies power to control panel, external siren and phone dialler. The GSM phone is powered and data fed by optional dedicated KB2 cable connected to white GSM socket on the panel pc board. The external siren should be connected to OUT1 alarm output. OUT 2 output signals the armed/disarmed status while OUT 3 – failure of 230VAC mains power. All three outputs may be connected to a phone dialler.

Figure 1. Sample installation diagram of a basic alarm system.

Elmes CB32 panel basic connection diagram

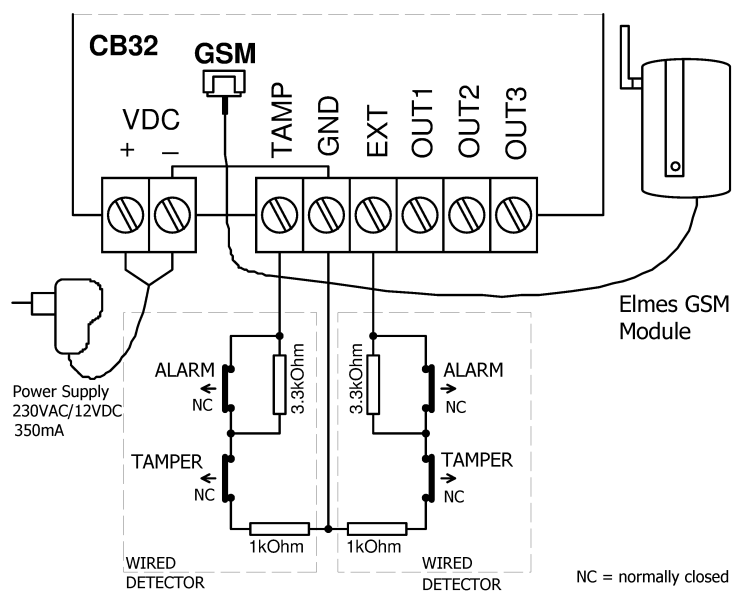
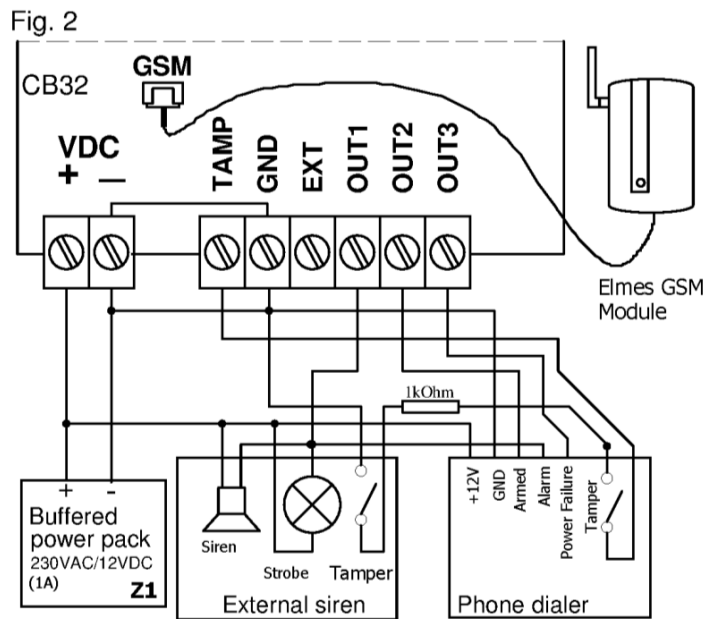

Figure 2. Sample diagram of alarm installation with a buffered power pack.



SPECIFICATION

- superheterodyne receiver 433.92 MHz, sensitivity better than -102dBm,
- supports up to 32 Elmes Electronic wireless detectors defined as alarm zones,
- supports two wired detectors connected to inputs EXT and TEMP,
- supports up to 16 named users (inclusive of 4 administrators),
- interface to a GSM phone (SMS/CLIP notification) accepting AT commands,
- non-volatile EEPROM memory of last 256 events,
- polymer fuse protected outputs OUT1-3 with up to 1A current draw,
- internal siren/buzzer with alarm sound level - 92dB (at 40cm distance),
- external AC/DC power pack with 9-20VDC output,
- current draw: 20mA (standby) + 40mA (panel backlit on) + 80mA (battery charging in CB32) + 100mA (alarming) + 80mA (GSM module battery charging) = 350mA maximum,
- backup power with two AA rechargeable batteries of up to 2500mAh each,
- up to 72 hours autonomy operation with two 1800mAh rechargeable batteries,
- external dimensions (without antenna): 110/122/32mm (width/height/thick),
- indoor use only with temperatures range from 0 to +40 °C.

Manufacturer: Elmes Electronic, 54-611 Wroclaw, Poland, ul. Avicenny 2,
phone +48717845961, fax+48717845963, e-mail: elmes@elmes.pl

LIMITED WARRANTY

The manufacturer of this product warrants the original purchaser that for a period of 24-months as from the date of purchase, the product shall be free of defects in materials and workmanship in normal use. During the warranty period, the manufacturer shall, at its option, repair or replace any defective product upon return of the product to the manufacturer, at no charge for labor and materials. The defective product must be delivered to the point of purchase in a clean condition and at buyer's own expense, along with this guarantee with the date of purchase confirmed below, and a short description of the failure. The cost of dismantling and installing the device is covered by the user. The warranty does not cover batteries and damage arising from improper use or handling, unauthorized adjustments, alterations and repairs.

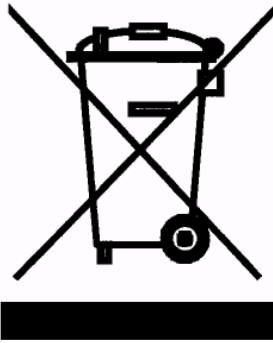

The use of WEEE symbol indicates that this product may not be treated as household waste. By ensuring this product is disposed of correctly you will protect the environment. For more detailed information about the recycling of this product, please contact your local authority, your household waste disposal service provider or the shop where you purchased the product.



FREQUENTLY ASKED QUESTIONS

1. ALARM led is flashing. What may be the cause?
- enter panel's Menu (press OK for more than 2 seconds) and check for reason. If it is battery failure then check for battery contacts, possible battery leakage or, set OFF battery failure notification (sub-menu 8.6), if batteries are not installed.
2. ALARM led is lit. What may be the cause?
- alarm occurred. Enter Menu and check zone number of the alarm and alarm time or, simply enter and leave the menu, the led light sets off.
3. Why occasionally sabotage (tamper) alarm is notified in zone 30?
- the reason is radio band jamming occurring in the area of panel installation. The jamming may be incidental or deliberate. User may set OFF the radio jamming protection function in sub-menu 8.2 of aux functions however, the entire wireless alarm system is not protected then against deliberate jamming of used radio band and burglary may not be notified.
4. Why sabotage alarm in zone 32 is set on after connecting power supply?
- the reason is panel's tamper switch not properly functioning. Check if plastic element protecting switch arm is removed. If not remove it and adjust its arm by gentle bending to signal the panel being moved off wall, or place of installation. Use washer to adjust proper distance of switch arm from wall. The other reason of the alarm may be lack of 1kOhm resistor in sabotage protection circuit (input TAMP).
- sabotage protection of OUT1 is set on (pt. 8.4) and no siren is connected to this output or, wires to the siren are cut off.
5. Despite CLIP call rejection, control panel calls three times with CLIP call notification ?
- in case of some mobile phone operators reaction to call rejection is "call recipient unavailable, please try later..." lasting up to 20 seconds. Only after then the control panel receives information that the call was rejected. Sometimes it is too late and the panel has already disconnected as the CLIP notification time has lapsed. This, in consequence, launch next connection attempts by the panel. To solve the issue, calling time should be prolonged at pt. 7.4 to 30-35 seconds or, calling recurrence set to OFF at pt. 7.10.5.